

25DU Tandem Dual Gooseneck Dump

G.V.W.R.	25,900#	AXLES	Two 10,000# Dual Wheel Oil Bath Electric Brakes
G.A.W.R. (Ea. Axle)	10,000#	SUSPENSION	Multi-Leaf Slipper Spring w/Equalizer
COUPLER	30K 2-5/16" Adjustable Crank Type	TIRE	ST235/80 D-16 Load Range E
SAFETY CHAINS	3/8" Grd. 70 w/Safety Latch Hook (2 each)	WHEEL	16 x 6 Dual 8 Bolt
JACKS	Two 12,000# Drop Leg Jacks (Bolted On)	FLOOR	10 Gauge Smooth Steel
NECK	12" I-Beam	LIGHTS	D.O.T. Stop, Tail, Turn & Clearance
FRAME	12" x 12# I-Beam	ELEC. PLUG	7-Way RV
FRAME CROSSMEMBERS	8" Channel	FINISH (Prep)	Steel is Cleaned to Ensure a Professional Smooth Finish.
BED CROSSMEMBERS	3" Channel	FINISH	Superior Quality Finish is Applied with Pin-Stripping for a Highly Decorative and Protective Finish.
BED LONG SILS	8" Channel		
SIDE RAILS	5" x 3" Angle		

Standard Features

- Safety Chains Attached w/Cold Rolled Eyelets
- Fully Enclosed Pump & Battery Box Between Gooseneck Uprights
- Lockable Control Unit
- 48" Sides w/Formed Channel Supports
- Double 1/2" Tie Rods on all 4 Sides
- Heavy Duty 10 Gauge Floor
- 4-5/8" D-Rings Inside Bed
- Self Contained Electric Hydraulic Scissor Lift
- 45 Degree Dump Angle
- Rubber Mounted Sealed Lighting & Modular Sealed Wiring Harness
- Complete Break-A-Way System w/Charge Line
- Spare Tire Mount
- Double Rear Gates w/Cam Latch
- Removable Header Across Rear

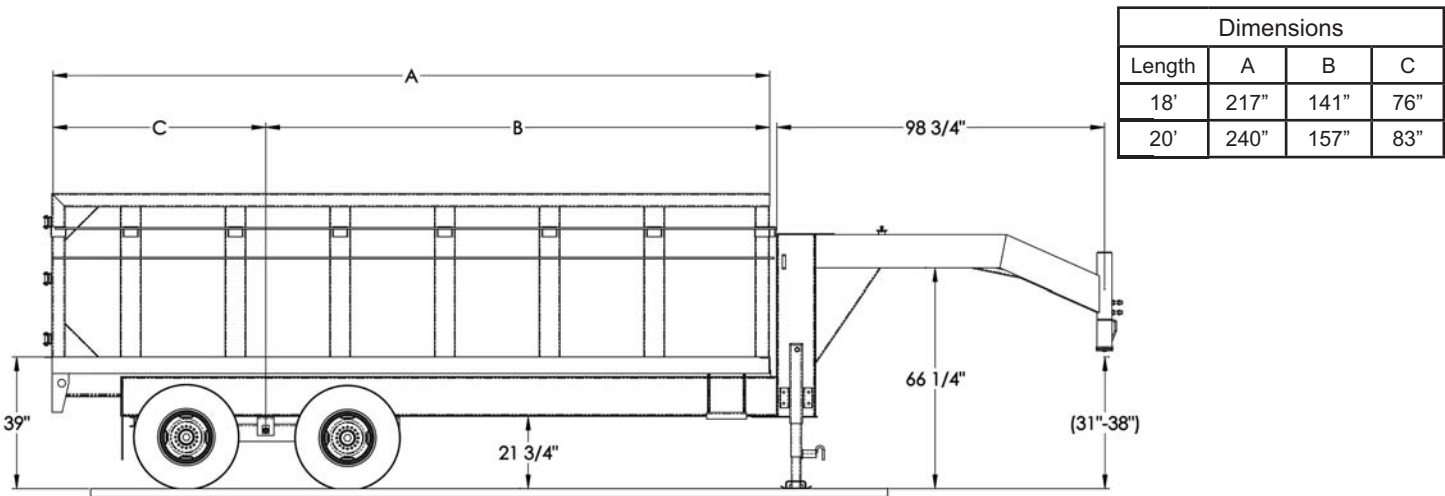

MODEL#	DESCRIPTION
25DU-18	92" x 18' Tandem Dual Gooseneck Dump
25DU-20	92" x 20' Tandem Dual Gooseneck Dump

TRAILER WEIGHTS & CAPACITIES

LENGTH	EMPTY WEIGHT	PAYLOAD	BOX CAPACITY
18'	8,100#	17,800#	21.98 Cubic Yards
20'	8,560#	17,340#	23.70 Cubic Yards

OPTIONS

Dual 2-Speed Landing Gear	5 Watt Solar Charger
Spare Tire (ST235/80 D-16 LR-E)	110V Charger
8' Slide In Ramps	Crank Style Roll Tarp
Wireless Remote	Roll Tarp w/Side Flaps
2 Watt Solar Charger	