

# 50DS Single Axle Low Profile Dump

<b>G.V.W.R.</b>	5,000#
<b>G.A.W.R. (Ea. Axle)</b>	5,080#
<b>COUPLER</b>	7K 2" Forged A-Frame
<b>SAFETY CHAINS</b>	1/4" Grd. 70 w/Safety Latch Hook (2 each)
<b>JACKS</b>	2,000# Top Wind (Bolted On)
<b>TONGUE</b>	5" Channel
<b>FRAME</b>	5" Channel
<b>CROSSMEMBERS</b>	3" X 3" Square Tubing
<b>BED CROSSMEMBERS</b>	2" x 2" Square Tubing
<b>BED LONG SILS</b>	3" Channel
<b>BED SIDE RAILS</b>	5" x 3" Formed Angle
<b>FENDERS</b>	9" x 36" Radius' D
<b>AXLE</b>	5,200# EZ Lube w/Elec. Brakes
<b>SUSPENSION</b>	Multi-Leaf Spring
<b>TIRE</b>	ST225/75-15 Load Range D
<b>WHEEL</b>	15 x 6 White Spoke 6 Bolt
<b>FLOOR</b>	12 Gauge Smooth Steel
<b>LIGHTS</b>	D.O.T. Stop, Tail, Turn & Clearance
<b>ELEC. PLUG</b>	7-Way RV
<b>FINISH (Prep)</b>	Steel is Cleaned to Ensure a Professional Smooth Finish.
<b>FINISH</b>	Superior Quality Finish is Applied with Pin-Stripping for a Highly Decorative and Protective Finish.

### Standard Features

- Safety Chains Attached w/Cold Rolled Eyelets
- Enclosed Pump & Battery Box Mounted in Front of Bed
- Lockable Control Unit
- 18", 12 Ga. Sides w/Formed Channel Supports
- 1 Piece 12 Ga. Floor
- 1/2" Tie Rail on all 4 Sides
- Stake Pockets (Sides & Front)
- Tarp Brackets
- Self Contained Electric/Hydraulic Scissor Lift
- 45 Degree Dump Angle
- Cambered EZ Lube Axle
- Complete Break-A-Way System w/Charge Line
- Grommet Mount Sealed Lighting
- Double Rear Doors

Dimensions			
Length	A	B	C
10'	120"	54"	66"

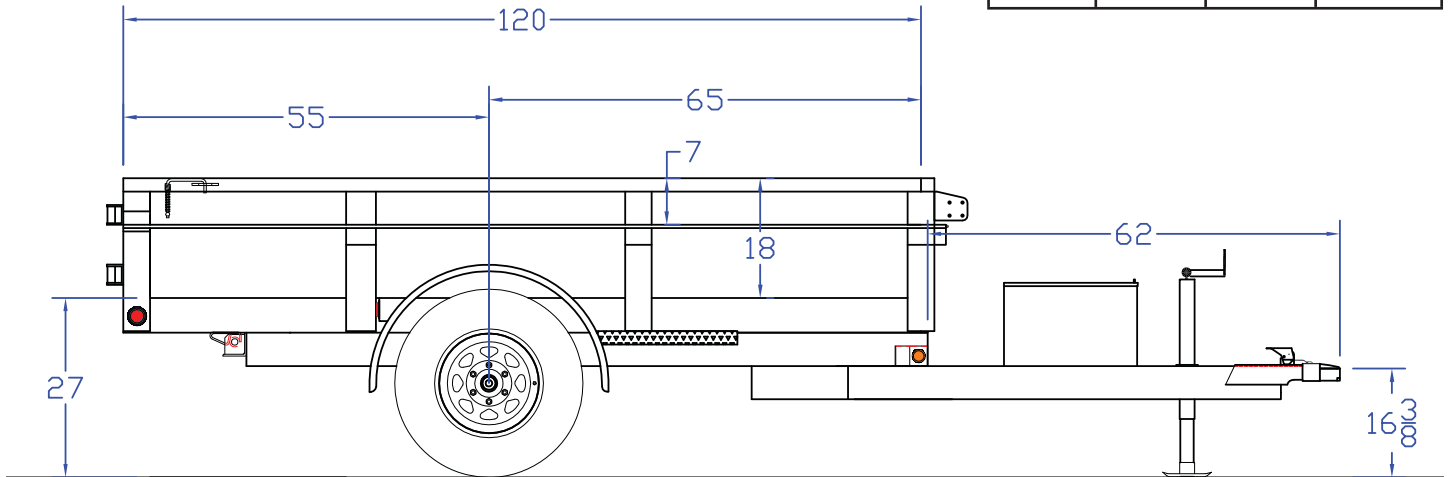

MODEL#	DESCRIPTION
50DS-10	60" x 10' Low Profile Single Axle Dump

### TRAILER WEIGHTS & CAPACITIES

LENGTH	EMPTY WEIGHT	PAYLOAD	BOX CAPACITY
10'	2,060#	2,940#	2.5 Cubic Yards

#### OPTIONS

Hydraulic Surge Brake	2 Watt Solar Charger
Spare Tire Mount	5 Watt Solar Charger
Spare Tire (ST225/75-15 LR-D)	110V Charger
Wireless Remote	Crank Style Roll Tarp