

14GN Tandem Axle Gooseneck

G.V.W.R. 15,900#	AXLES Two 7,000# EZ Lube w/Electric Brakes
G.A.W.R. (Ea. Axle) 7,000#	SUSPENSION Multi-Leaf Slipper Spring w/Equalizer
COUPLER 2-5/16" Ball Adj. Pipe, 3" ID Pintle on PH	TIRE ST235/16 Load Range E
SAFETY CHAINS 3/8" Grd. 70 w/Safety Latch Hook (2 each)	WHEEL 16 x 6 HD White Modular 8 Bolt
JACKS Dual 12K Drop Leg Jacks (Bolted On), Single 12K TW on PH	FLOOR 2" Pine
NECK 12" I-Beam	LIGHTS LED D.O.T. Stop, Tail, Turn & Clearance
TOP RAIL None	ELEC. PLUG 7-Way RV
FRAME 12" I-Beam	FINISH (Prep) Steel is Cleaned to Ensure a Professional Smooth Finish.
CROSSMEMBERS 3" Channel	FINISH Superior Quality Finish is Applied for a Highly Decorative and Protective Finish.
SIDE RAILS 5" Channel w/Rub Rail, Stake Pockets on 24" Centers, and Chain Spools	

Standard Features

- Safety Chains Attached w/Cold Rolled Eyelets
- Dual Drop Leg Jacks (Single Speed) Bolted on w/Greasable Handle
- Pintle has Single TW Drop Leg Jack
- 102" Overall Width
- Low Profile Bed, Pierced Frame
- Lockable Toolbox Between GN Uprights
- 2 Side Bed Steps
- 3/8" Heavy Duty Rub Rail
- 1-1/4" Pipe Chain Spool Between Stake Pockets
- Safety Reflective Marker Tape
- Floor Secured w/Torx Screws
- Cambered EZ Lube Axles w/Electric Brake on Each
- Complete Break-A-Way System w/Battery & Charger
- Radial Tires on HD Wheels
- Spare Tire Mount
- Modular Sealed Wiring Harness
- Rubber Mounted Sealed LED Lighting
- 5' Dovetail w/Double Hinged Spring Assist Fold Over Ramps

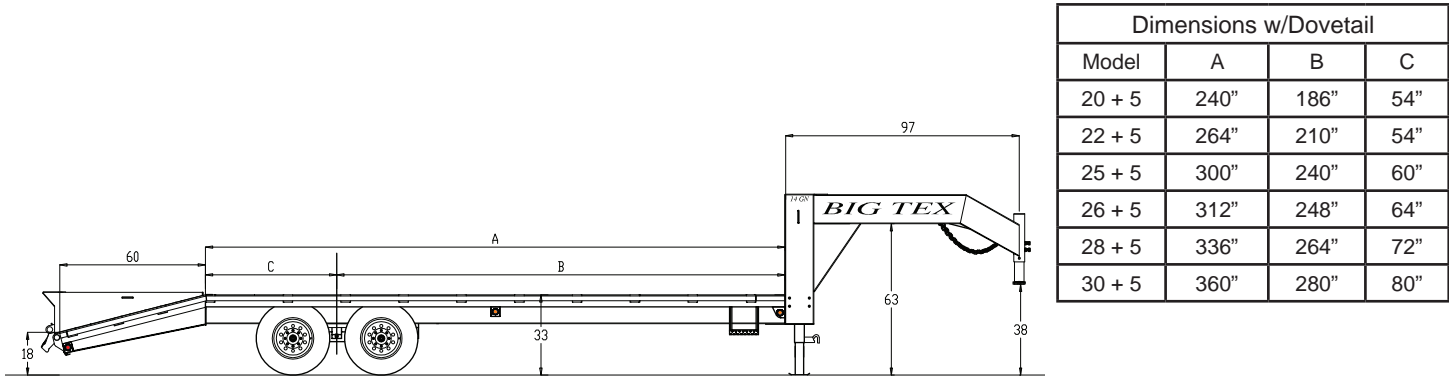

MODEL#	WEIGHT	DESCRIPTION
14GN-20+5	4,920#	102" x 20' + 5' Tandem 14,000# Gooseneck/Pintle
14GN-22+5	5,120#	102" x 22' + 5' Tandem 14,000# Gooseneck/Pintle
14GN-25+5	5,340#	102" x 25' + 5' Tandem 14,000# Gooseneck/Pintle
14GN-26+5	5,590#	102" x 26' + 5' Tandem 14,000# Gooseneck/Pintle
14GN-28+5	5,880#	102" x 28' + 5' Tandem 14,000# Gooseneck/Pintle
14GN-30+5	6,130#	102" x 30' + 5' Tandem 14,000# Gooseneck/Pintle

OPTIONS

30K Square Adjustable Screw Type Coupler	Low Profile Tool Box 15" x 15" x 36" (Side Mount)
Dual Two Speed Landing Gear	Tool Box 18" x 18" x 36" (Side Mount)
Electric Over Hydraulic Brakes (Drums)	5' Center Pop-Up Dovetail w/5' Fold Up Ramps
Torsion Axles	No Dovetail Option
Spare Tire (ST235/80 R-16 LR-E)	Three Ramps w/Diamond Plate on Bottoms
Tire Upgrade (ST235/85 R-16 LR-G)	Mega Ramps
Spare Tire Upgrade (ST235/85 R-16 LR-G)	Pintle in Lieu of Gooseneck